



ZUBADAN PUHZ-SHW80-112VAA/YAA Specifications

p o w e r e d b y

COP

rendszer technika kft

English

Model Name			PUHZ-SHW80VAA(-BS)	PUHZ-SHW80YAA(-BS)
Power supply (phase, cycle, voltage)			1φ, 230V, 50Hz	3φ, 400V, 50Hz
	Max. current	A	22.0	13.0
Breaker size			25.0	16.0
Outer casing			Galvanized plate	Galvanized plate
External finish			Munsell: N8.75 Munsell N2.75 (FRONT PANEL)	Munsell: N8.75 Munsell N2.75 (FRONT PANEL)
Refrigerant control			Linear expansion valve	Linear expansion valve
Compressor			Hermetic scroll	Hermetic scroll
	Model		DNK28FBAMT	DNK28FBBMT
	Motor output	kW	2.2	2.2
Start type			Inverter	Inverter
Protection devices			HP switch LP switch Discharge thermo Overcurrent detection Comp. surface thermo	HP switch LP switch Discharge thermo Overcurrent detection Comp. surface thermo
	Oil (Model)	L	1.00 (FVC68D)	1.00 (FVC68D)
Crankcase heater			-	-
Heat exchanger		Air	Plate fin coil	Plate fin coil
		Water	-	-
Fan	Fan(drive) x No.		Propeller fan x 1	Propeller fan x 1
	Fan motor output	kW	0.2	0.2
	Air flow	m ³ /min (CFM)	50 (1,760)	50 (1,760)
Defrost method			Reverse cycle	Reverse cycle
Noise level (SPL)	Heating	dB(A)	45	45
	Cooling	dB(A)	48	48
Noise level (PWL)	Heating	dB(A)	59	59
Dimensions	Width	mm(in)	1050 (41-5/16)	1050 (41-5/16)
	Depth	mm(in)	480 (18-7/8)	480 (18-7/8)
	Height	mm(in)	1020 (40-3/16)	1020 (40-3/16)
Weight		kg(lbs)	116 (256)	128 (282)
Refrigerant (GWP)			R410A (1975)	R410A (1975)
	Quantity	kg(lbs)	4.6 (10.1)	4.6 (10.1)
Pipe size O.D.	Liquid	mm(in)	9.52 (3/8)	9.52 (3/8)
	Gas	mm(in)	15.88 (5/8)	15.88 (5/8)
Connection method			Flared	Flared
Between the indoor & outdoor unit	Height difference	m	Max. 30	Max. 30
	Piping length	m	2 to 75	2 to 75
Guaranteed operating range (Outdoor)	Heating	°C	-28 to +21	-28 to +21
	DHW	°C	-28 to +35	-28 to +35
	Cooling*	°C	-15 to +46	-15 to +46
Outlet water temp. (Max in heating, Min in cooling)	Heating	°C	+60	+60
	Cooling	°C	+5	+5
Nominal return water temperature range	Heating	°C	+5 to +59	+5 to +59
	Cooling	°C	+8 to +28	+8 to +28
Water flow rate range		L/min	10.2 to 22.9	10.2 to 22.9

* Optional air protection guide is required where ambient temperature is lower than -5°C.
The temperature is 10°C when the unit is connected with Cylinder unit or Hydrobox.
For more details, refer to "Cylinder unit / Hydrobox".

Model Name			PUHZ-SHW112VAA(-BS)	PUHZ-SHW112YAA(-BS)
Power supply (phase, cycle, voltage)			1φ, 230V, 50Hz	3φ, 400V, 50Hz
	Max. current	A	28.0	13.0
Breaker size			32.0	16.0
Outer casing			Galvanized plate	Galvanized plate
External finish			Munsell: N8.75 Munsell N2.75 (FRONT PANEL)	Munsell: N8.75 Munsell N2.75 (FRONT PANEL)
Refrigerant control			Linear expansion valve	Linear expansion valve
Compressor			Hermetic scroll	Hermetic scroll
	Model		DNK28FBAMT	DNK28FBBMT
	Motor output	kW	2.2	2.2
Start type			Inverter	Inverter
Protection devices			HP switch LP switch Discharge thermo Overcurrent detection Comp. surface thermo	HP switch LP switch Discharge thermo Overcurrent detection Comp. surface thermo
	Oil (Model)	L	1.00 (FVC68D)	1.00 (FVC68D)
Crankcase heater			W	-
Heat exchanger		Air	Plate fin coil	Plate fin coil
		Water	-	-
Fan	Fan(drive) x No.		Propeller fan x 1	Propeller fan x 1
	Fan motor output	kW	0.2	0.2
	Air flow	m ³ /min (CFM)	50 (1,760)	50 (1,760)
Defrost method			Reverse cycle	Reverse cycle
Noise level (SPL)	Heating	dB(A)	47	47
	Cooling	dB(A)	49	49
Noise level (PWL)	Heating	dB(A)	60	60
Dimensions	Width	mm(in)	1050 (41-5/16)	1050 (41-5/16)
	Depth	mm(in)	480 (18-7/8)	480 (18-7/8)
	Height	mm(in)	1020 (40-3/16)	1020 (40-3/16)
Weight		kg(lbs)	116 (256)	128 (282)
Refrigerant (GWP)			R410A (1975)	R410A (1975)
	Quantity	kg(lbs)	4.6 (10.1)	4.6 (10.1)
Pipe size O.D.	Liquid	mm(in)	9.52 (3/8)	9.52 (3/8)
	Gas	mm(in)	15.88 (5/8)	15.88 (5/8)
Connection method			Flared	Flared
Between the indoor & outdoor unit	Height difference	m	Max. 30	Max. 30
	Piping length	m	2 to 75	2 to 75
Guaranteed operating range (Outdoor)	Heating	°C	-28 to +21	-28 to +21
	DHW	°C	-28 to +35	-28 to +35
	Cooling*	°C	-15 to +46	-15 to +46
Outlet water temp. (Max in heating, Min in cooling)	Heating	°C	+60	+60
	Cooling	°C	+5	+5
Nominal return water temperature range	Heating	°C	+5 to +59	+5 to +59
	Cooling	°C	+8 to +28	+8 to +28
Water flow rate range		L/min	14.4 to 32.1	14.4 to 32.1

* Optional air protection guide is required where ambient temperature is lower than -5°C.
The temperature is 10°C when the unit is connected with Cylinder unit or Hydrobox.
For more details, refer to "Cylinder unit / Hydrobox".

Model name		PUHZ-SHW230YKA2	
Nominal water flow rate (Heating mode)		L/min	65.9
Heating (A7/W35)	Capacity	kW	23.00
	COP		3.65
	Power input	kW	6.31
Heating (A2/W35)	Capacity	kW	23.00
	COP		2.37
	Power input	kW	9.71
Pressure difference (water circuit)		kPa	-
Heating pump input (based on EN14511)		kW	-
Nominal water flow rate (Cooling mode)		L/min	57.3
Cooling (A35/W7)	Capacity	kW	20.00
	EER (COP)		2.22
	Power input	kW	9.01
Cooling (A35/W18)	Capacity	kW	20.00
	EER (COP)		3.55
	Power input	kW	5.63
Pressure difference (water circuit)		kPa	-
Cooling pump input (based on EN14511)		kW	-
Recommended plate heat exchanger		ACH70-40 x 2 Parallel connection	

The table shows performance data obtained when a plate heat exchanger is connected.

Model name		PUHZ-SHW80VAA(-BS)		PUHZ-SHW80YAA(-BS)	
Nominal water flow rate (Heating mode)		L/min	22.9	22.9	
Heating (A7/W35)	Capacity	kW	8.0	8.0	
	COP		4.65	4.65	
	Power input	kW	1.72	1.72	
Heating (A2/W35)	Capacity	kW	8.0	8.0	
	COP		3.55	3.55	
	Power input	kW	2.25	2.25	
Pressure difference (water circuit)		kPa	-	-	
Heating pump input (based on EN14511)		kW	-	-	
Nominal water flow rate (Cooling mode)		L/min	20.4	20.4	
Cooling (A35/W7)	Capacity	kW	7.1	7.1	
	EER (COP)		3.31	3.31	
	Power input	kW	2.15	2.15	
Cooling (A35/W18)	Capacity	kW	7.1	7.1	
	EER (COP)		4.52	4.52	
	Power input	kW	1.57	1.57	
Pressure difference (water circuit)		kPa	-	-	
Cooling pump input (based on EN14511)		kW	-	-	
Recommended plate heat exchanger		MWA2-38PA		MWA2-38PA	

The table shows performance data obtained when a plate heat exchanger is connected.

Model name		PUHZ-SHW112VAA(-BS)	PUHZ-SHW112YAA(-BS)
Nominal water flow rate (Heating mode)		L/min	32.1
Heating (A7/W35)	Capacity	kW	11.2
	COP		4.46
	Power input	kW	2.51
Heating (A2/W35)	Capacity	kW	11.2
	COP		3.22
	Power input	kW	3.48
Pressure difference (water circuit)		kPa	-
Heating pump input (based on EN14511)		kW	-
Nominal water flow rate (Cooling mode)		L/min	28.7
Cooling (A35/W7)	Capacity	kW	10.0
	EER (COP)		2.83
	Power input	kW	3.53
Cooling (A35/W18)	Capacity	kW	10.0
	EER (COP)		4.74
	Power input	kW	2.11
Pressure difference (water circuit)		kPa	-
Cooling pump input (based on EN14511)		kW	-
Recommended plate heat exchanger		MWA2-38PA	MWA2-38PA

The table shows performance data obtained when a plate heat exchanger is connected.

■ Inverter multi

Model name		PUMY-P112V/YKM(E)3(-BS)	PUMY-P125V/YKM(E)3(-BS)	PUMY-P140V/YKM(E)3(-BS)
Nominal water flow rate (Heating mode)		L/min	35.8	35.8
Heating (A7/W35)	Capacity	kW	12.5	12.5
	COP*		4.08	4.08
	Power input	kW	3.06	3.06
Heating (A2/W35)	Capacity	kW	10.0	10.0
	COP*		2.86	2.86
	Power input	kW	3.50	3.50
Pressure difference (water circuit)		kPa	-	-
Heating pump input (based on EN14511)		kW	-	-
Recommended plate heat exchanger		MWA2-38-PA-4	MWA2-38-PA-4	MWA2-38-PA-4

The table shows performance data obtained when a plate heat exchanger is connected.

* In case of ATW unit single connection, the COP for ATW heating decreases depending on the number of connected ATA units (Refer to the figure below).

ATW COP reduction ratio by ATA indoor units

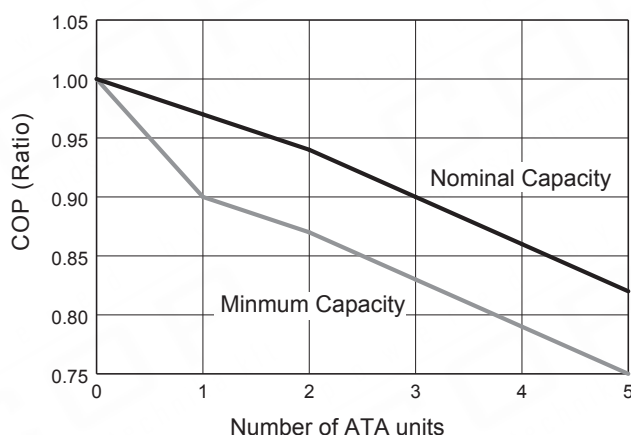

	0	1	2	3	4	5
Nominal Capacity	1.00	0.97	0.94	0.90	0.86	0.82
Minimum Capacity	1.00	0.90	0.87	0.83	0.79	0.75

■Zubadan

- PUHZ-SHW80/112VHA(-BS)**
- PUHZ-SHW112/140YHA(-BS)**
- PUHZ-SHW230YKA2**

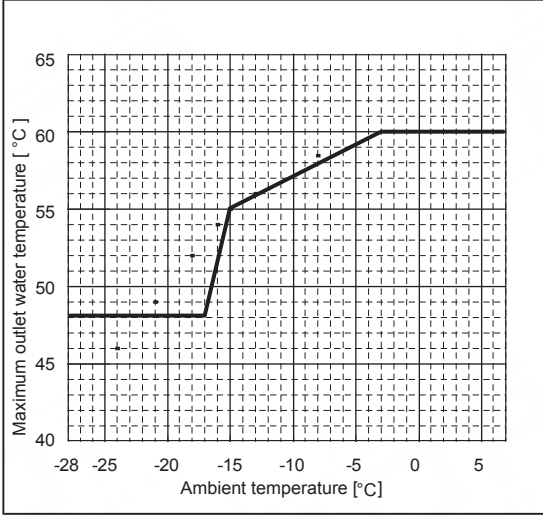

- PUHZ-SHW80/112VAA(-BS)**
- PUHZ-SHW80/112YAA(-BS)**

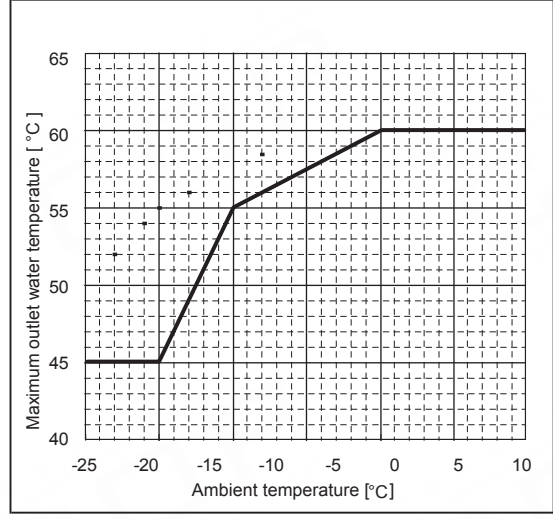

*PUHZ-SHW80/112/140 Service reference number from "R2": down to -28°C
Before "R2" and PUHZ-SHW230 : down to -25°C

■Inverter multi

- PUMY-P112/125/140VKM3(-BS)**
- PUMY-P112/125/140YKM3(-BS)**
- PUMY-P112/125/140YKME3(-BS)**

Maximum outlet water temperature curve at single operation of ATW Heating

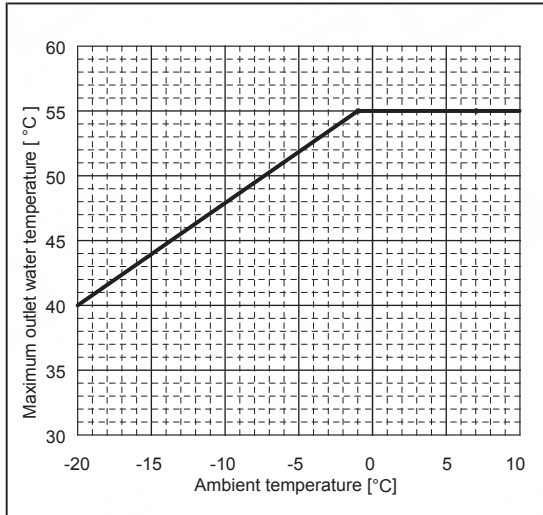

Maximum outlet water temperature curve at simultaneous operation of ATA Heating and ATW heating

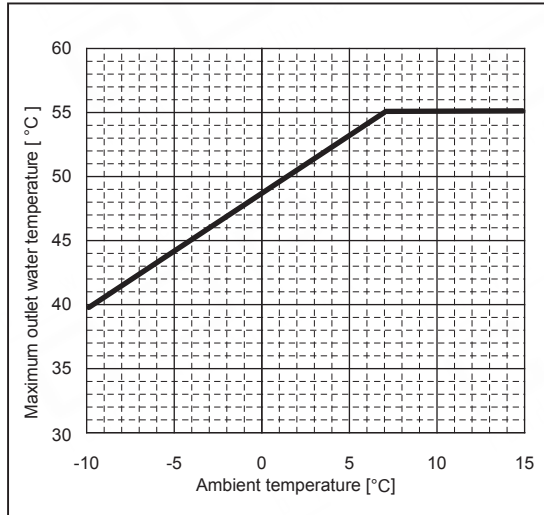

(2) Split-type units*

* When a recommended plate heat exchanger is installed.

■ Heating

SUHZ-SW45VA(H)
PUHZ-SW50VKA(-BS)

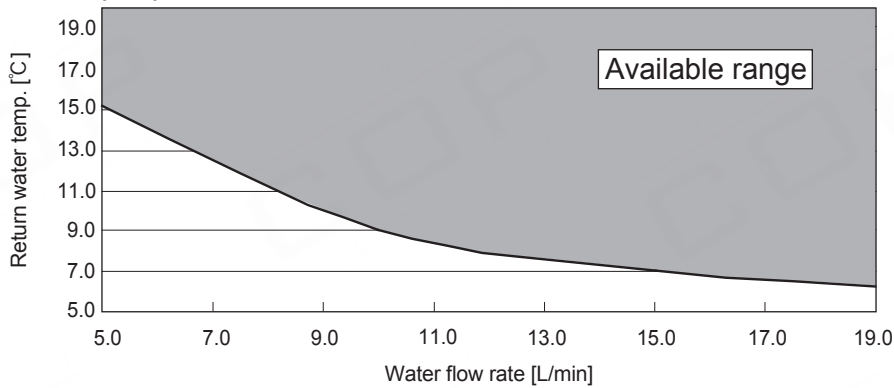

PUHZ-SW75VHA(-BS) **PUHZ-SW75VAA(-BS)**
PUHZ-SHW80VHA(-BS) **PUHZ-SW75YAA(-BS)**

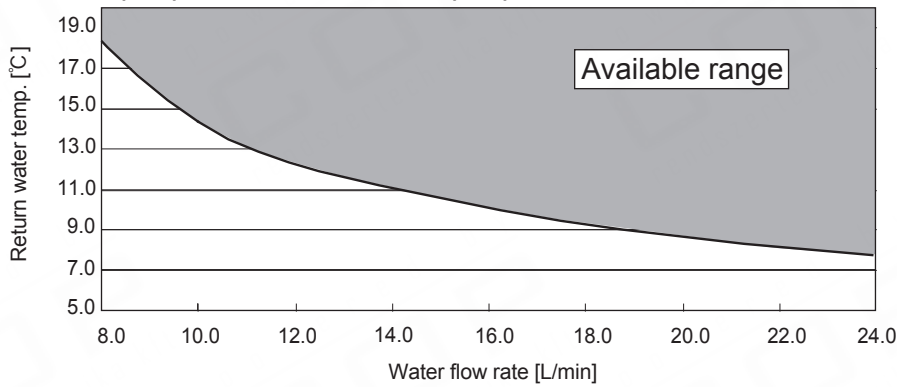

PUHZ-SW100/120VHA(-BS) **PUHZ-SHW112VHA(-BS)**
PUHZ-SW100/120YHA(-BS) **PUHZ-SHW112/140YHA(-BS)**
PUHZ-SW100VAA(-BS) **PUHZ-SHW80/112VAA(-BS)**
PUHZ-SW100YAA(-BS) **PUHZ-SHW80/112YAA(-BS)**

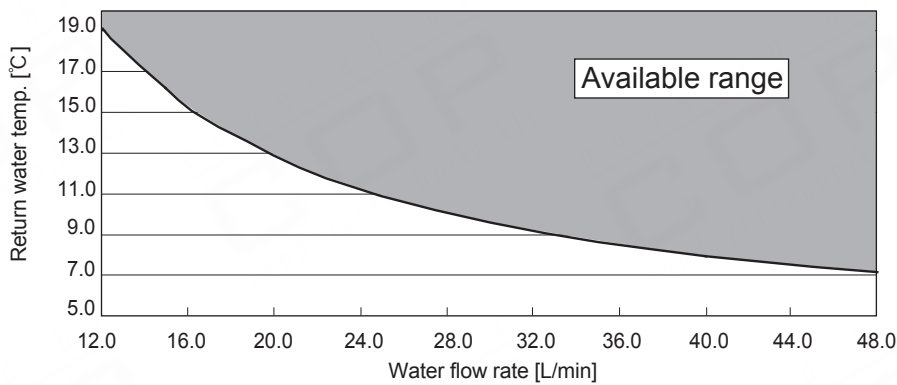

PUHZ-SW160YKA(-BS) **PUHZ-SW200YKA(-BS)**

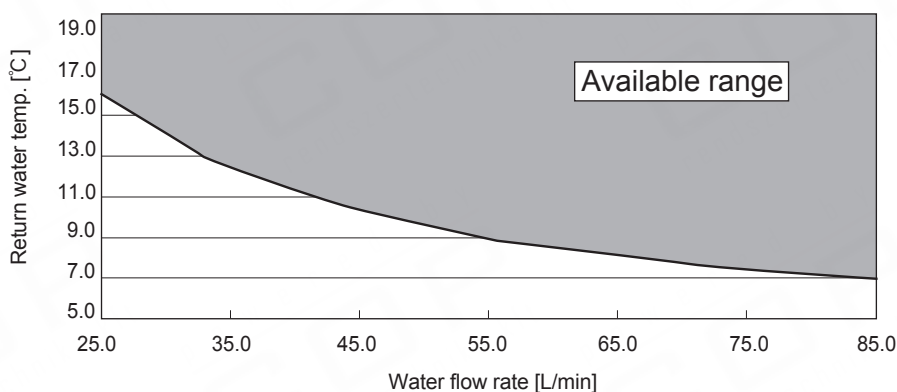

■ Cooling

SUHZ-SW45VA(H)
PUHZ-SW50VKA(-BS)

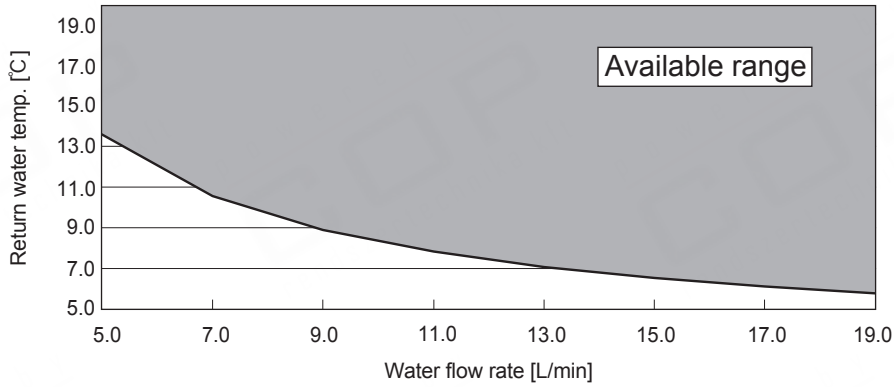

PUHZ-SW75VHA(-BS) **PUHZ-SW75VAA(-BS)**
PUHZ-SW75YHA(-BS) **PUHZ-SW75YAA(-BS)**

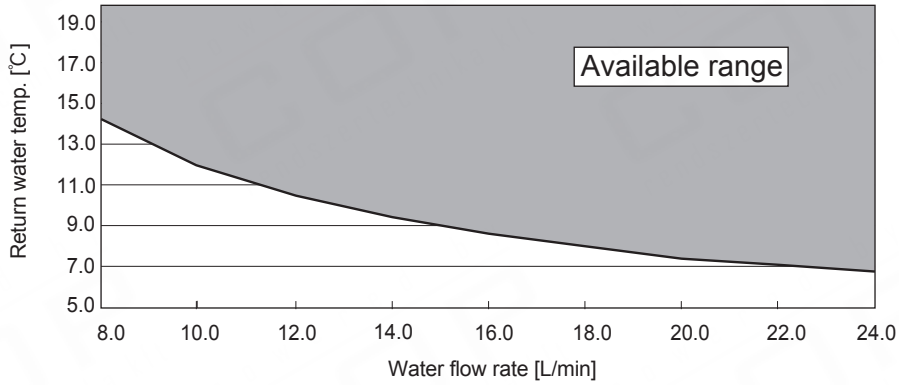

PUHZ-SW100VHA(-BS) **PUHZ-SHW80/112VHA(-BS)**
PUHZ-SW100YHA(-BS) **PUHZ-SHW112/140YHA(-BS)**
PUHZ-SW100VAA(-BS) **PUHZ-SHW80/112VAA(-BS)**
PUHZ-SW100YAA(-BS) **PUHZ-SHW80/112YAA(-BS)**

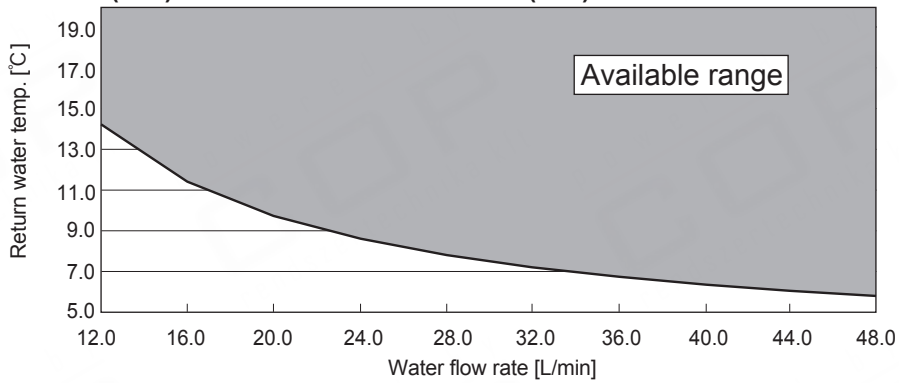

PUHZ-SW120VHA(-BS)
PUHZ-SW120YHA(-BS)

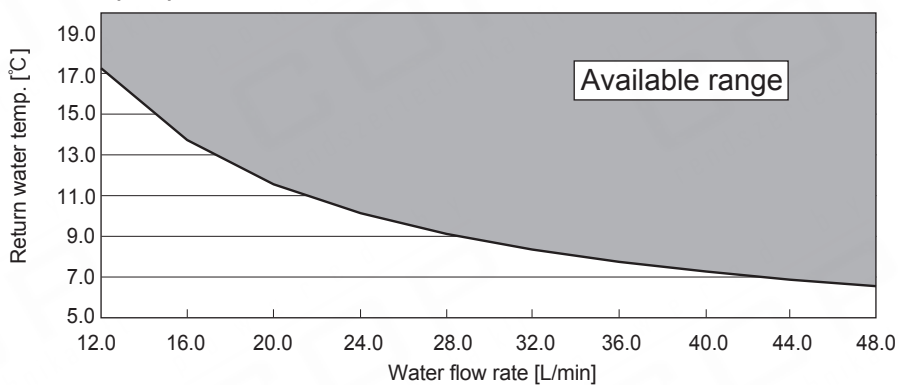

- PUAZ-SW75/100VAA(-BS)
- PUAZ-SW75/100YAA(-BS)
- PUAZ-SHW80/112VAA(-BS)
- PUAZ-SHW80/112YAA(-BS)

Unit : mm

Outdoor unit

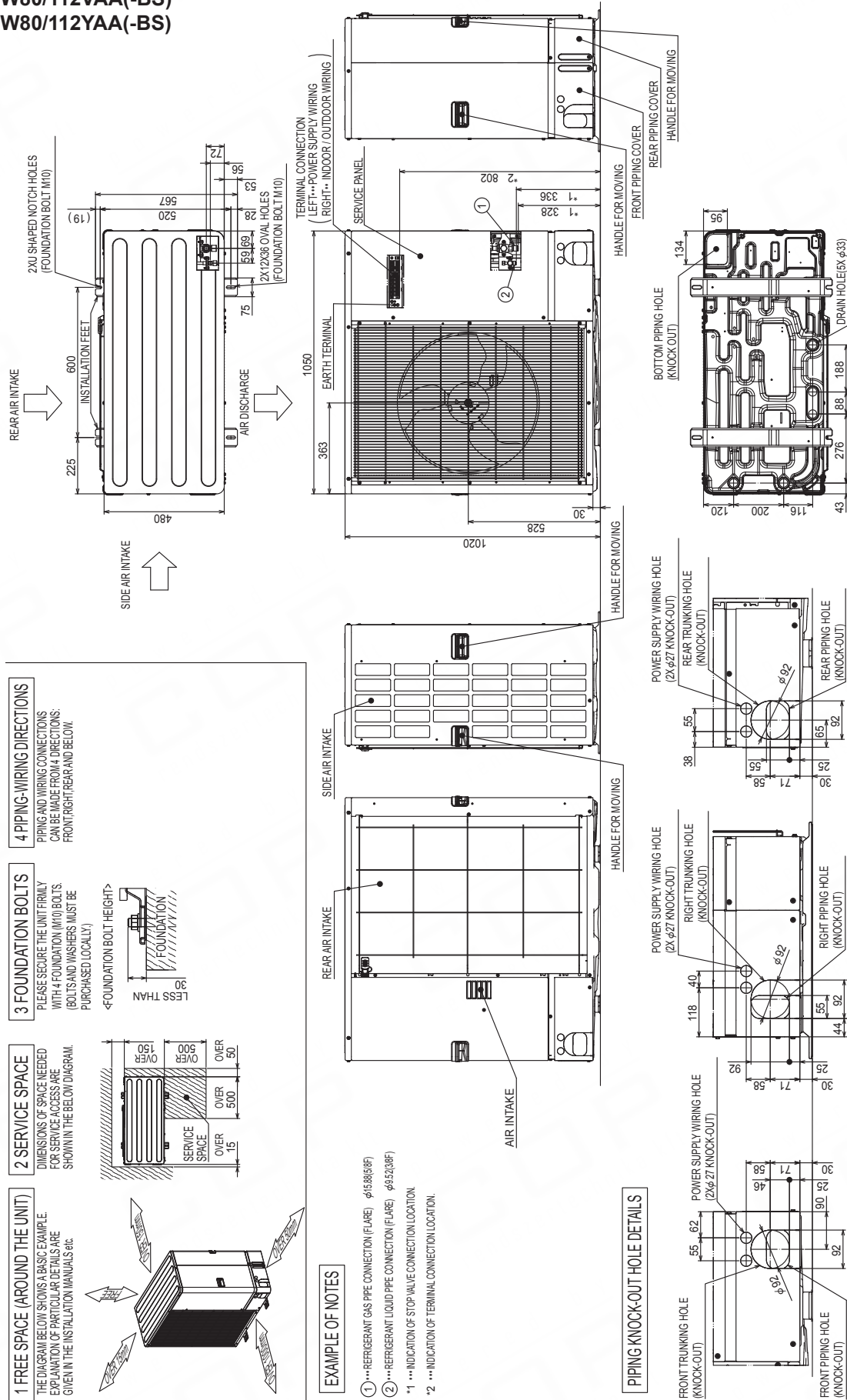

PUHZ-SHW80/112YAA(-BS)

Outdoor unit

SYMBOL	NAME	SYMBOL	NAME	SYMBOL	NAME
TB1	Terminal Block <Power Supply>	TH33	Thermistor <Comp. Surface>	SW5	Switch <Function Switch>
TB2	Terminal Block <Indoor/Outdoor>	LEV-A, LEV-B, LEV-C	Linear Expansion Valve	SW6	Switch <Function Switch, Model Select>
MC	Motor for Compressor	ACL1, ACL2, ACL3, ACL4	Reactor	SW7	Switch <Function Switch>
MF1	Fan Motor	CY1, CY2	Capacitor	SW8	Switch <Function Switch>
21S4	Solenoid Valve (4-Way Valve)	CK	Capacitor	SW9	Switch <Function Switch>
63H	High Pressure Switch	RS	Rush Current Protect Resistor	SWP	Switch <Pump Down>
63L	Low Pressure Switch	P. B.	Power Circuit Board	CNDM	Connector <Connection for Option>
63HS	High Pressure Sensor	N. F.	Noise Filter Circuit Board	SV1/CH	Connector <Connection for Option>
TH3	Thermistor <Liquid>	C. B.	Controller Circuit Board	SV3/SS	Connector <Connection for Option>
TH4	Thermistor <Discharge>	CONV. B.	Converter Circuit Board	CNM	Connector <Connection for Option>
TH6	Thermistor <2-Phase Pipe>	C. B.	Controller Circuit Board	F1, F2, F3, F4	Fuse <T6,3AL250V>
TH7	Thermistor <Ambient>	SW1	Switch <Manual Defrost, Defect History Record, Reset, Refrigerant Address>		
TH8	Thermistor <Heat Sink>	SW4	Switch <Function Switch>		
TH32	Thermistor <Suction>				

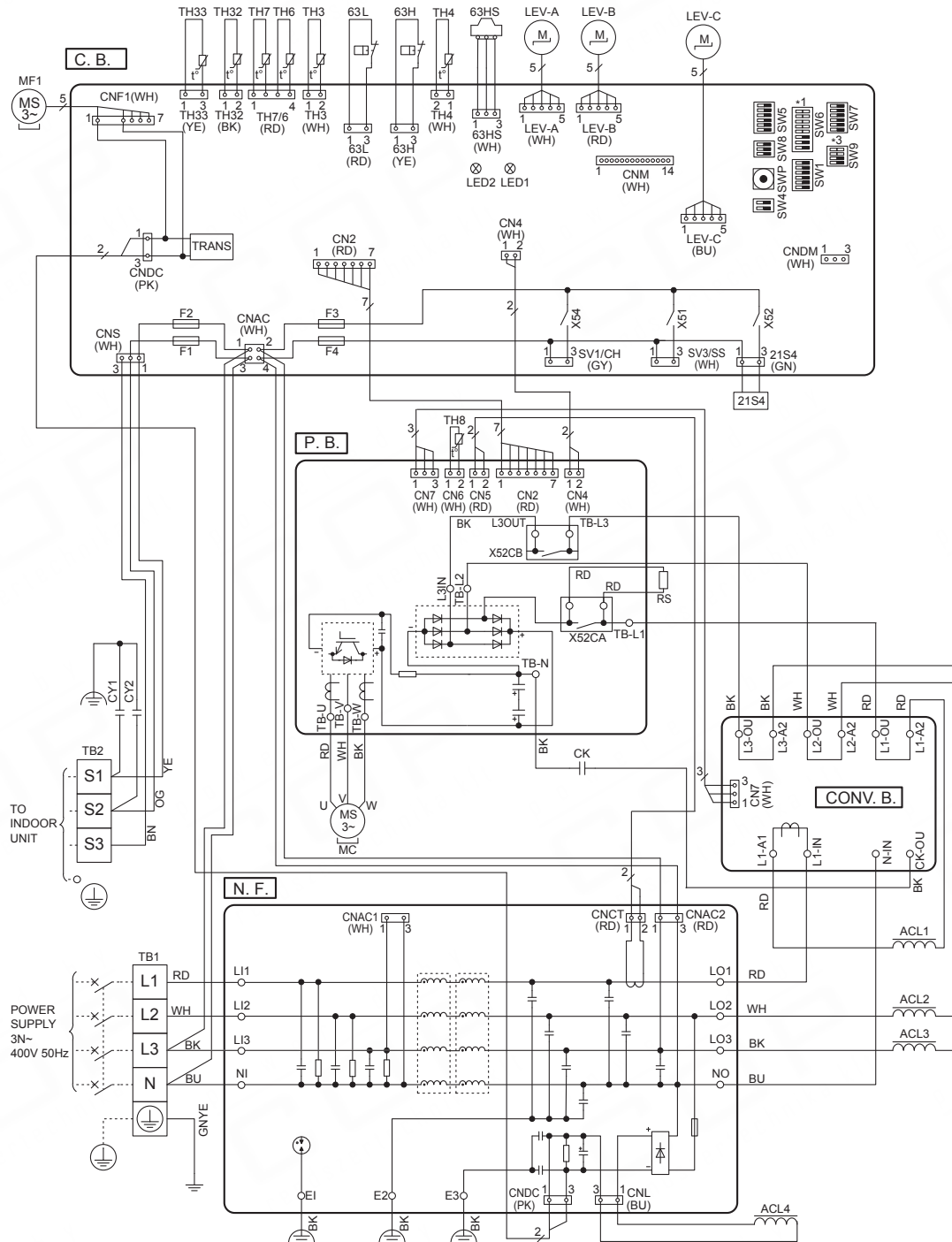

*2 SW6 -1 to 3 : Function Switch

*3 Ambient temp. of ZUBADAN Flash Injection becomes effective. The black square (■) indicates a switch position.

Ambient temp.	SW9-3, 9-4 *4	Ambient temp.	SW9-3, 9-4 *4	Ambient temp.	SW9-3, 9-4 *4
3°C or less (Default setting)	ON OFF <input type="checkbox"/> <input type="checkbox"/> <input type="checkbox"/> <input type="checkbox"/>	0°C or less	ON OFF <input type="checkbox"/> <input type="checkbox"/> <input type="checkbox"/> <input type="checkbox"/>	-3°C or less	ON OFF <input type="checkbox"/> <input type="checkbox"/> <input type="checkbox"/> <input type="checkbox"/>
	1 2 3 4		1 2 3 4		1 2 3 4

*4 SW9-1 to 2 : Function Switch

*1 MODEL SELECT The black square (■) indicates a switch position.

MODEL	SW6 *2
80Y	ON OFF <input type="checkbox"/> <input type="checkbox"/> <input type="checkbox"/> <input type="checkbox"/> <input type="checkbox"/> <input type="checkbox"/> <input type="checkbox"/> <input type="checkbox"/>
	1 2 3 4 5 6 7 8
MODEL	SW6 *2
112Y	ON OFF <input type="checkbox"/> <input type="checkbox"/> <input type="checkbox"/> <input type="checkbox"/> <input type="checkbox"/> <input type="checkbox"/> <input type="checkbox"/> <input type="checkbox"/>
	1 2 3 4 5 6 7 8

Outdoor unit

■ PUAZ-SHW80/112VAA(-BS)

PUHZ-SHW80/112YAA(-BS)

Unit : mm (inch)

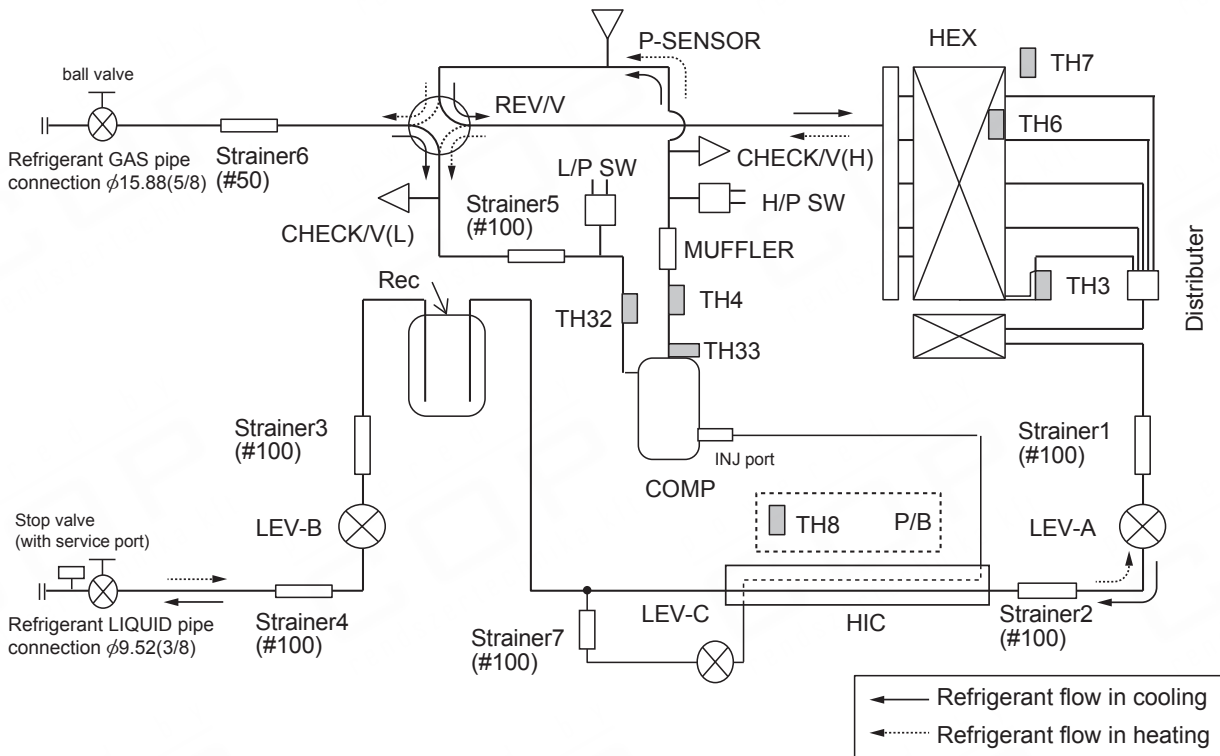

■ PUMY-P112VKM3(-BS)
PUMY-P112YKM3(-BS)
PUMY-P112YKME3(-BS)

PUMY-P125VKM3(-BS)
PUMY-P125YKM3(-BS)
PUMY-P125YKME3(-BS)

PUMY-P140VKM3(-BS)
PUMY-P140YKM3(-BS)
PUMY-P140YKME3(-BS)

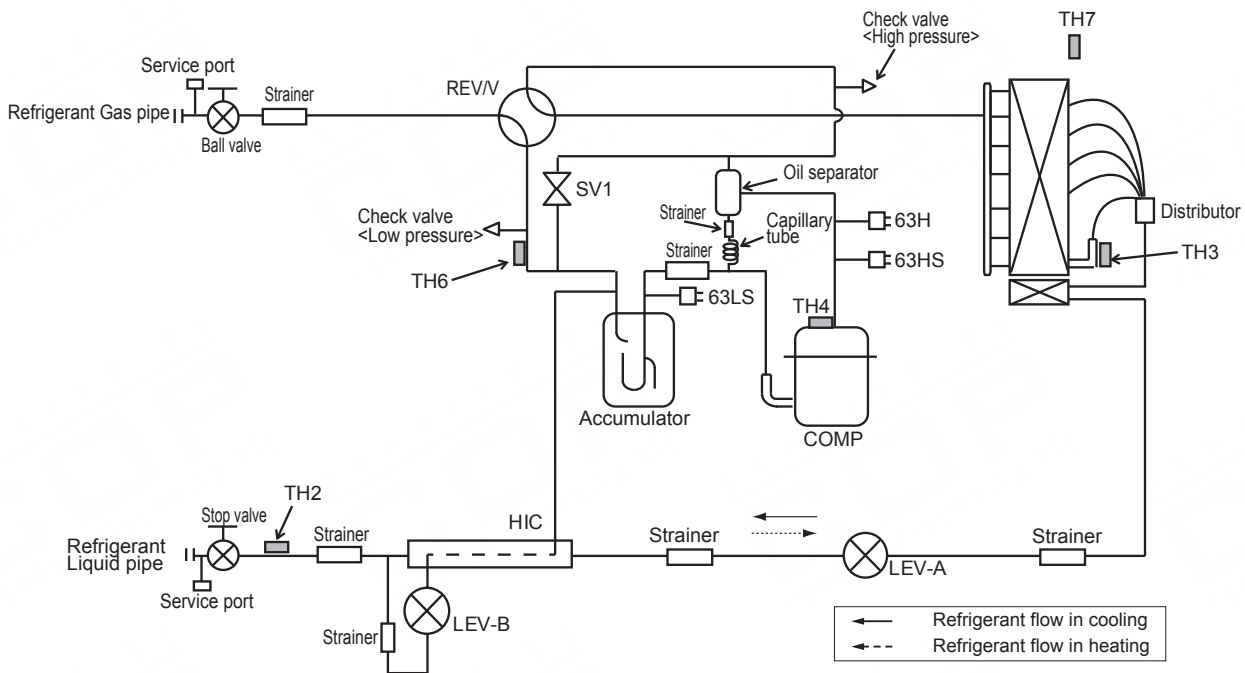

5 Performance data

Outdoor unit

Outdoor unit



■ PUHZ-SHW80V/YAA(-BS)

Water outlet temperature[°C]		25		35		40		45		50		55		60	
Ambient temperature[°C]		Capacity	COP	Capacity	COP	Capacity	COP	Capacity	COP	Capacity	COP	Capacity	COP	Capacity	COP
Max	(INJ) -20	-	-	7.3	2.23	7.0	1.94	6.8	1.68	-	-	-	-	-	-
	(INJ) -15	-	-	8.7	2.63	8.4	2.30	8.0	2.00	7.7	1.84	7.4	1.59	-	-
	(INJ) -10	10.8	3.65	10.2	3.04	9.9	2.64	9.5	2.28	9.2	1.98	8.8	1.71	-	-
	(INJ) -7	9.7	3.99	9.2	3.32	8.9	2.88	8.6	2.49	8.3	2.16	8.0	2.02	-	-
	(INJ) 2	9.4	4.09	8.9	3.41	8.6	2.96	8.3	2.71	8.0	2.49	7.7	2.15	7.4	1.86
	7	9.9	5.36	9.3	4.47	9.0	3.87	8.7	3.35	8.4	2.90	8.1	2.69	7.7	2.17
	12	11.6	6.29	10.9	5.24	10.6	4.54	10.2	3.93	9.9	3.40	9.5	2.94	9.1	2.55
	15	12.6	6.87	11.9	5.72	11.5	4.96	11.1	4.29	10.7	3.72	10.3	3.21	9.9	2.78
Nominal	(INJ) -20	-	-	7.3	2.23	7.0	1.94	6.8	1.68	-	-	-	-	-	-
	(INJ) -15	-	-	8.0	2.74	8.0	2.38	8.0	2.00	7.7	1.84	7.4	1.59	-	-
	(INJ) -10	8.0	3.52	8.0	2.93	8.0	2.55	8.0	2.26	8.0	1.96	8.0	1.70	-	-
	(INJ) -7	8.0	4.17	8.0	3.48	8.0	3.02	8.0	2.68	8.0	2.33	8.0	2.02	-	-
	(INJ) 2	8.0	4.26	8.0	3.55	8.0	3.20	8.0	2.85	8.0	2.49	7.7	2.15	7.4	1.86
	7	8.0	5.58	8.0	4.65	8.0	4.05	8.0	3.42	8.0	3.12	8.0	2.70	7.7	2.17
	12	8.0	6.54	8.0	5.45	8.0	4.74	8.0	4.20	8.0	3.65	8.0	3.16	8.0	2.78
	15	8.0	7.14	8.0	5.95	8.0	5.18	8.0	4.58	8.0	3.99	8.0	3.45	8.0	3.03
Mid	-20	-	-	5.8	2.42	5.6	2.10	5.4	1.86	-	-	-	-	-	-
	-15	-	-	6.4	2.95	6.4	2.57	6.4	2.27	6.4	1.98	6.4	1.71	-	-
	-10	6.4	3.87	6.4	3.22	6.4	2.80	6.4	2.48	6.4	2.16	6.4	1.87	-	-
	-7	6.4	4.34	6.4	3.62	6.4	3.15	6.4	2.79	6.4	2.42	6.4	2.10	-	-
	2	6.4	4.43	6.4	3.70	6.4	3.21	6.4	2.85	6.4	2.48	6.4	2.14	6.4	1.88
	7	6.4	5.65	6.4	4.71	6.4	4.10	6.4	3.63	6.4	3.16	6.4	2.73	6.4	2.40
	12	6.4	6.47	6.4	5.39	6.4	4.69	6.4	4.15	6.4	3.61	6.4	3.13	6.4	2.75
	15	6.4	6.97	6.4	5.81	6.4	5.06	6.4	4.47	6.4	3.89	6.4	3.37	6.4	2.96
Min	-20	-	-	5.0	2.37	4.8	2.06	4.7	1.78	4.5	1.54	-	-	-	-
	-15	-	-	5.7	2.68	5.5	2.32	5.3	2.01	5.1	1.74	4.9	1.51	-	-
	-10	3.7	3.42	3.5	2.85	3.4	2.47	3.2	2.14	3.1	1.85	3.0	1.60	-	-
	-7	3.8	3.53	3.6	2.94	3.5	2.55	3.4	2.21	3.2	1.91	3.1	1.65	-	-
	2	3.9	4.56	3.7	3.80	3.6	3.29	3.5	2.85	3.3	2.47	3.2	2.13	3.1	1.85
	7	3.6	5.38	3.4	4.48	3.3	3.89	3.2	3.36	3.1	2.91	3.0	2.52	2.8	2.18
	12	4.3	6.38	4.1	5.32	4.0	4.61	3.8	3.99	3.7	3.45	3.6	2.99	3.4	2.58
	15	4.7	6.92	4.5	5.77	4.3	5.00	4.2	4.33	4.0	3.74	3.9	3.24	3.7	2.80

■ PUHZ-SHW112V/YAA(-BS)

Water outlet temperature[°C]		25		35		40		45		50		55		60	
Ambient temperature[°C]		Capacity	COP	Capacity	COP	Capacity	COP	Capacity	COP	Capacity	COP	Capacity	COP	Capacity	COP
Max	(INJ) -20	-	-	10.2	2.02	10.0	1.79	9.7	1.57	-	-	-	-	-	-
	(INJ) -15	-	-	11.9	2.30	11.6	2.04	11.2	1.80	10.8	1.56	10.4	1.35	-	-
	(INJ) -10	12.8	2.34	12.2	2.12	11.9	2.13	11.5	2.13	11.2	2.01	10.8	1.74	-	-
	(INJ) -7	12.8	2.62	12.2	2.37	11.9	2.38	11.5	2.39	11.2	2.25	10.8	1.95	-	-
	(INJ) 2	12.3	2.62	11.7	3.16	11.4	2.87	11.2	2.60	10.8	2.25	10.4	1.94	9.9	1.68
	7	13.9	4.88	13.1	4.07	12.7	3.52	12.3	3.05	11.8	2.64	11.4	2.70	10.9	1.98
	12	16.1	5.50	15.2	4.58	14.7	3.97	14.2	3.44	13.7	2.98	13.2	2.57	12.6	2.23
	15	17.4	5.86	16.4	4.88	15.9	4.23	15.4	3.66	14.8	3.17	14.3	2.74	13.7	2.37
Nominal	-20	-	-	10.2	2.02	10.0	1.79	9.7	1.57	-	-	-	-	-	-
	(INJ) -15	-	-	11.2	2.37	11.2	2.05	11.2	1.80	10.8	1.56	10.4	1.35	-	-
	(INJ) -10	11.2	3.57	11.2	2.98	11.2	2.58	11.2	2.26	11.2	2.01	10.8	1.74	-	-
	(INJ) -7	11.2	4.01	11.2	3.34	11.2	2.89	11.2	2.54	11.2	2.25	10.8	1.95	-	-
	(INJ) 2	11.2	3.86	11.2	3.22	11.2	2.90	11.2	2.60	10.8	2.25	10.4	1.94	9.9	1.68
	7	11.2	5.35	11.2	4.46	11.2	3.87	11.2	3.39	11.2	3.01	11.2	2.71	10.9	1.98
	12	11.2	6.56	11.2	5.46	11.2	4.74	11.2	4.15	11.2	3.68	11.2	3.32	11.2	2.84
	15	11.2	7.26	11.2	6.05	11.2	5.24	11.2	4.60	11.2	4.08	11.2	3.67	11.2	3.14
Mid	(INJ) -20	-	-	8.2	2.14	8.0	1.89	7.7	1.66	-	-	-	-	-	-
	(INJ) -15	-	-	9.0	2.51	9.0	2.17	9.0	1.90	8.6	1.65	8.3	1.43	-	-
	(INJ) -10	9.0	3.78	9.0	3.15	9.0	2.73	9.0	2.39	9.0	2.12	8.6	1.84	-	-
	(INJ) -7	9.0	4.24	9.0	3.53	9.0	3.06	9.0	2.68	9.0	2.38	8.6	2.06	-	-
	(INJ) 2	9.0	4.09	9.0	3.41	9.0	3.07	9.0	2.75	8.6	2.38	8.3	2.06	8.0	1.78
	7	9.0	5.66	9.0	4.72	9.0	4.09	9.0	3.59	9.0	3.18	9.0	2.86	8.7	2.09
	12	9.0	6.94	9.0	5.16	9.0	4.48	9.0	3.87	9.0	3.35	9.0	2.90	9.0	2.51
	15	9.0	7.68	9.0	5.71	9.0	4.95	9.0	4.29	9.0	3.71	9.0	3.21	9.0	2.77
Min	-20	-	-	5.0	2.37	4.8	2.06	4.7	1.78	4.5	1.54	-	-	-	-
	-15	-	-	5.7	2.68	5.5	2.32	5.3	2.01	5.1	1.74	4.9	1.51	-	-
	-10	3.7	3.42	3.5	2.85	3.4	2.47	3.2	2.14	3.1	1.85	3.0	1.60	-	-
	-7	3.8	3.53	3.6	2.94	3.5	2.55	3.4	2.21	3.2	1.91	3.1	1.65	-	-
	2	3.9	4.56	3.7	3.80	3.6	3.29	3.5	2.85	3.3	2.47	3.2	2.13	3.1	1.85
	7	3.6	5.38	3.4	4.48	3.3	3.89	3.2	3.36	3.1	2.91	3.0	2.52	2.8	2.18
	12	4.3	6.38	4.1	5.32	4.0	4.61	3.8	3.99	3.7	3.45	3.6	2.99	3.4	2.58
	15	4.7	6.92	4.5	5.77	4.3	5.00	4.2	4.33	4.0	3.74	3.9	3.24	3.7	2.80

■ Zubadan

Water outlet temperature[°C]		35		45		55	
Ambient temperature[°C]		Capacity	COP	Capacity	COP	Capacity	COP
PUHZ-SHW 80VHA(-BS)	-7	7.18	3.20	7.33	2.46	7.40	1.97
	2	7.54	3.68	7.35	3.00	7.21	2.33
		6.82	4.06	6.72	3.15	6.66	2.46
7	6.15	4.82	6.03	3.70	5.79	2.90	
PUHZ-SHW 112V/YHA(-BS)	-7	7.16	3.18	7.31	2.45	7.38	1.96
	2	7.52	3.66	7.33	2.99	7.19	2.32
		6.80	4.04	6.70	3.13	6.64	2.45
7	6.13	4.80	6.01	3.68	5.77	2.89	
PUHZ-SHW 140YHA(-BS)	-7	7.14	3.18	7.29	2.44	7.36	1.96
	2	7.50	3.65	7.31	2.98	7.17	2.31
		6.79	4.03	6.69	3.13	6.63	2.44
7	6.12	4.79	6.00	3.67	5.76	2.88	
PUHZ-SHW 230YKA2	-7	16.68	2.95	19.41	2.37	20.98	2.13
	2	13.20	3.45	13.04	2.59	12.91	2.27
		12.49	3.55	12.22	2.73	12.00	2.33
7	11.43	4.31	13.94	3.17	15.42	2.50	
PUHZ-SHW 80V/YAA(-BS)	 -7	8.00	3.48	8.00	2.68	8.00	2.02
	-7	4.95	3.32	4.78	2.62	4.59	2.07
	2	8.00	3.55	7.73	2.80	7.42	2.21
		6.81	3.99	6.58	3.15	6.32	2.48
	7	6.81	4.64	6.58	3.67	6.32	2.89
PUHZ-SHW 112V/YAA(-BS)	 -7	11.20	3.34	11.2	2.54	10.76	1.95
	-7	4.94	3.31	4.77	2.61	4.59	2.06
	2	8.96	3.41	8.65	2.69	8.32	2.12
		6.80	3.98	6.57	3.14	6.31	2.48
	7	6.80	4.63	6.57	3.66	6.31	2.88

 : This icon means injection circuit is active.

■ Inverter multi In case of ATW unit single connection

Water outlet temperature[°C]		35		45		55	
Ambient temperature[°C]		Capacity	COP	Capacity	COP	Capacity	COP
PUMY-P 112/125/140 V/YKM(E)3(-BS)	-7	5.95	2.84	6.40	2.21	—	—
	2	6.14	3.14	6.18	2.61	6.39	1.86
		5.17	3.33	5.15	2.87	5.39	1.95
7	8.50	4.37	8.30	3.35	8.18	2.50	

Outdoor unit

PUHZ-SHW230YKA2

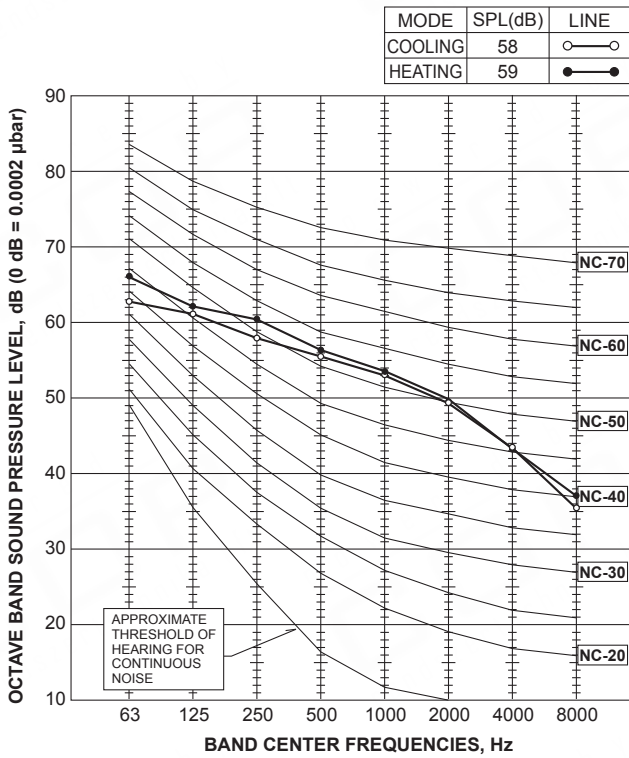

PUHZ-SHW80VAA(-BS) PUHZ-SHW80YAA(-BS)

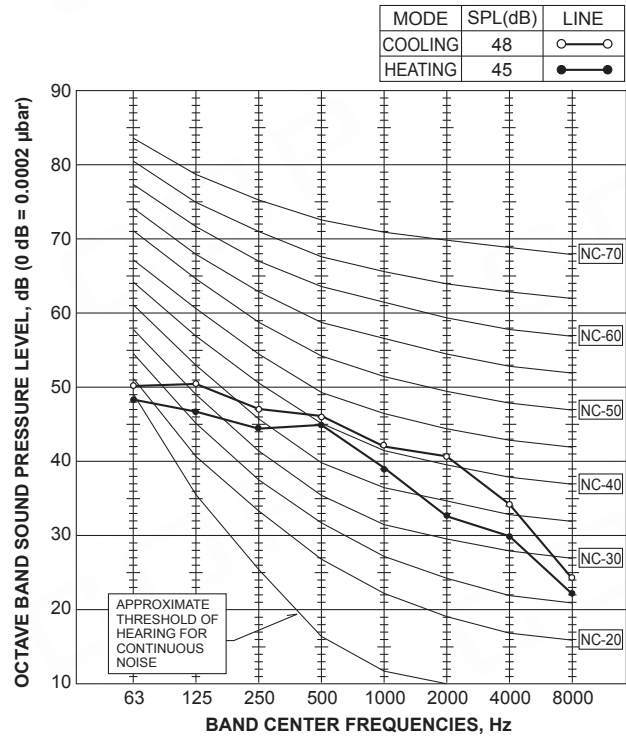

PUHZ-SHW112VAA(-BS) PUHZ-SHW112YAA(-BS)

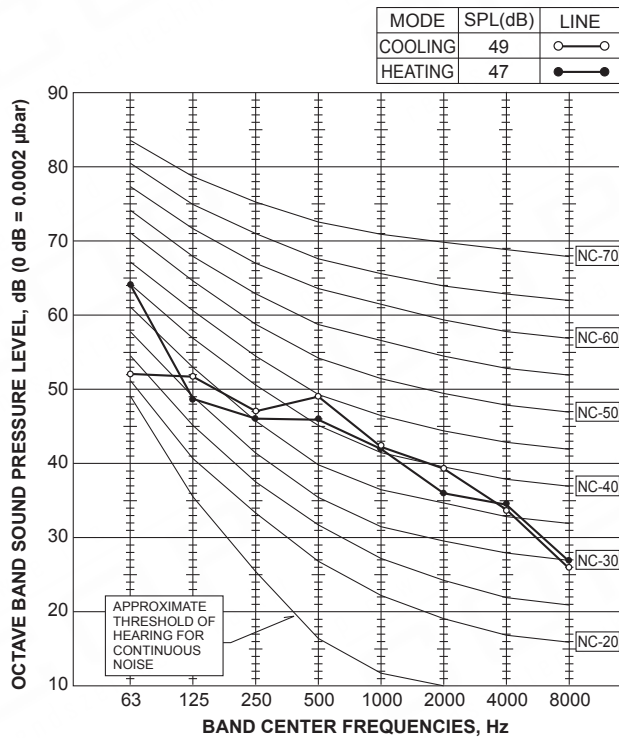

<Notes>

- 1) Sound data is taken when the system is running stably.
- 2) Relatively large noise could be heard transiently in the case 4-way valve, or LEV operates.

1.Type: ZUBADAN Outdoor unit

2.Model name: PUHZ-SHW80/112YAA(-BS)

3.Specification

- | | |
|---|--|
| (1) Unit mass | W= 128 kg |
| (2) Anchor bolt | |
| 1.The total number of bolts | N= 4 |
| 2.The size and shape | "=M 10 type |
| 3.The axis section area per one bolt | A= 78 mm ² = 78 × 10 ⁻⁶ m ² |
| 4.The total number of bolts in one side which be pulled stronger when the unit inverted | Nt= 2 |
| (3) The height between the installing surface and the center of gravity of the unit | Hg= 470 mm= 0.47 m |
| (4) The bolt-span from the examination angle | L= 520 mm= 0.52 m |
| (5) The distance between the center of bolt and the center of gravity of the unit | Lg= 215 mm(Lg≤L/2)= 0.215 m |

4.The examination calculation (by rounding off to the first decimal place of each item)

- | | |
|--|--|
| (1) The horizontal seismic coefficient for designing | Kh= 1.0 |
| (2) The vertical seismic coefficient for designing | Kv=Kh/2= 0.5 |
| (3) The horizontal earthquake forces for designing | Fh=Kh·W·9.8= 1254.4 N |
| (4) The vertical earthquake forces for designing | Fv=Kv·W·9.8= 627.2 N |
| (5) The withdrawal strength of the anchor bolt | $R_b = \frac{F_h \cdot H_g - (W \cdot 9.8 - F_v) \cdot L_g}{L \cdot N_t}$
= 437.2 N |
| (6) The shear forces of the anchor bolt | Q=Fh/N= 313.6 N |
| (7) The stress arising to the anchor bolt | |
| 1.The tensile stress | $\sigma = R_b/A = 5.6$ MPa < ft=176.4MPa |
| 2.The shearing stress | $\tau = Q/A = 4.0$ MPa < fs=132.3MPa |
| 3.The stress when affected by both the shearing and the tensile at the same time | $f_t s = 1.4f_t - 1.6\tau = 240.5$ MPa
< fts= 176.4 MPa |
| | $\sigma = 5.6$ MPa |
| (8) The construction way of the anchor bolt | |
| 1.The construction way of the anchor bolt | = Boxed J type anchor |
| 2.The thickness of the concrete | = 120 mm= 0.120 m |
| 3.The length of buried part of bolt | = 70 mm= 0.070 m |
| 4.The permissible withdrawal weight | Ta= 3136 N > Rb 437.2 N |

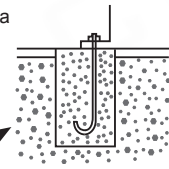

Since the results from the examination above, the anchor bolt has enough strength.

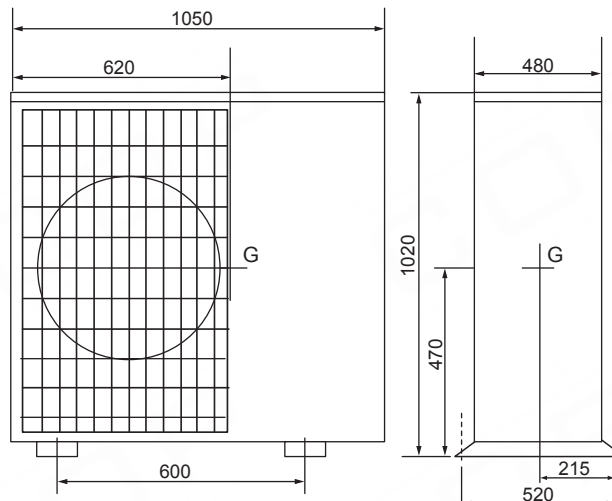

PUHZ-SHW80/112VAA(-BS), PUHZ-SHW80/112YAA(-BS)

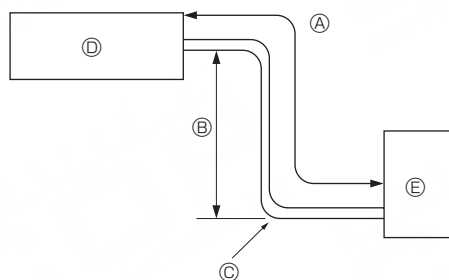

Fig. 4-19

(mm)

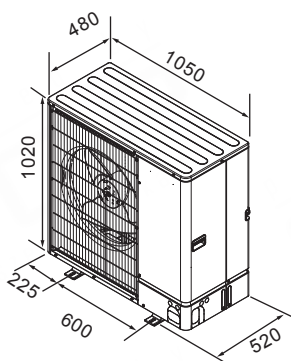

Fig. 4-20

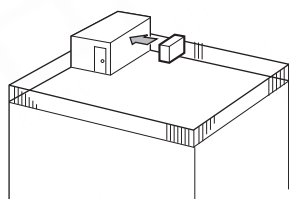

Fig. 4-21

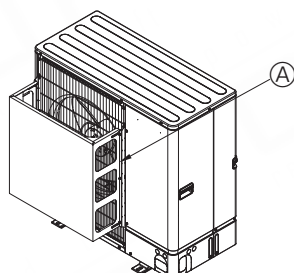

Fig. 4-22

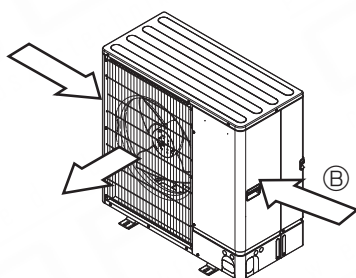

Fig. 4-23

Refrigerant pipe (Fig. 4-19)

- ▶ Check that the difference between the heights of the indoor and outdoor units, the length of refrigerant pipe, and the number of bends in the pipe are within the limits shown below.

Model	Ⓐ Pipe length (one way)	Ⓑ Height difference	Ⓒ Number of bends (one way)
SHW80, 112	2 m - 75 m	Max. 30 m	Max. 15

- Height difference limitation is defined regardless of which unit, indoor or outdoor, is positioned higher.

- Ⓓ Indoor unit
- Ⓔ Outdoor unit

Choosing the outdoor unit installation location

- Avoid locations exposed to direct sunlight or other sources of heat.
- Select a location from which noise emitted by the unit will not inconvenience neighbors.
- Select a location permitting easy wiring and pipe access to the power source and indoor unit.
- Avoid locations where combustible gases may leak, be produced, flow, or accumulate.
- Note that water may drain from the unit during operation.
- Select a level location that can bear the weight and vibration of the unit.
- Avoid locations where the unit can be covered by snow. In areas where heavy snow fall is anticipated, special precautions such as raising the installation location or installing a hood on the air intake must be taken to prevent the snow from blocking the air intake or blowing directly against it. This can reduce the airflow and a malfunction may result.
- Avoid locations exposed to oil, steam, or sulfuric gas.
- Use the transportation handles of the outdoor unit to transport the unit. If the unit is carried from the bottom, hands or fingers may be pinched.

Outline dimensions (Outdoor unit) (Fig. 4-20)

Ventilation and service space

(1) Windy location installation

When installing the outdoor unit on a rooftop or other location unprotected from the wind, situate the air outlet of the unit so that it is not directly exposed to strong winds. Strong wind entering the air outlet may impede the normal airflow and a malfunction may result.

The following shows three examples of precautions against strong winds.

- ① Face the air outlet towards the nearest available wall about 35 cm away from the wall. (Fig. 4-21)
- ② Install an optional air guide if the unit is installed in a location where strong winds from a typhoon, etc. may directly enter the air outlet. (Fig. 4-22)
 - Ⓐ Air outlet guide
- ③ Position the unit so that the air outlet blows perpendicularly to the seasonal wind direction, if possible. (Fig. 4-23)
 - Ⓑ Wind direction

(2) When installing a single outdoor unit (Refer to the next page)

Minimum dimensions are as follows, except for Max., meaning Maximum dimensions, indicated. Refer to the figures for each case.

- ① Obstacles at rear only (Fig. 4-24)
- ② Obstacles at rear and above only (Fig. 4-25)
 - Do not install the optional air outlet guides for upward airflow.
- ③ Obstacles at rear and sides only (Fig. 4-26)
- ④ Obstacles at front only (Fig. 4-27)
- ⑤ Obstacles at front and rear only (Fig. 4-28)
- ⑥ Obstacles at rear, sides, and above only (Fig. 4-29)
 - Do not install the optional air outlet guides for upward airflow.

(3) When installing multiple outdoor units (Refer to the next page)

Leave 50 mm space or more between the units.

Refer to the figures for each case.

- ① Obstacles at rear only (Fig. 4-30)
- ② Obstacles at rear and above only (Fig. 4-31)
 - No more than 3 units must be installed side by side. In addition, leave space as shown.
 - Do not install the optional air outlet guides for upward airflow.
- ③ Obstacles at front only (Fig. 4-32)
- ④ Obstacles at front and rear only (Fig. 4-33)
- ⑤ Single parallel unit arrangement (Fig. 4-34)
 - * When using an optional air outlet guide installed for upward airflow, the clearance is 500 mm or more.
- ⑥ Multiple parallel unit arrangement (Fig. 4-35)
 - * When using an optional air outlet guide installed for upward airflow, the clearance is 1000 mm or more.
- ⑦ Stacked unit arrangement (Fig. 4-36)
 - The units can be stacked up to two units high.
 - No more than 2 stacked units must be installed side by side. In addition, leave space as shown.